

# Cerebral State Monitor

Model CSM 2

## User Manual



danmeter

Danmeter A/S

Kildemosevej 13, DK-5000 Odense C, Denmark

Tel.: +45 63 11 29 30

Fax: +45 63 11 29 31

e-mail: [info@danmeter.dk](mailto:info@danmeter.dk)

[www.danmeter.dk](http://www.danmeter.dk)





## Table of Contents

1	About this Manual.....	1
1.1	Indications for Use.....	1
1.2	List of Symbols.....	2
2	Installation and Preparation.....	2
3	Skin Preparation and Sensor Positioning.....	3
4	Description of the Device.....	4
4.1	General Overview.....	4
4.2	Keys and Controls Overview.....	5
4.3	Light Indicators.....	6
4.4	Description of Keys.....	6
4.5	Operation Display Modes.....	8
4.6	Setup Menu.....	10
4.7	Settings.....	11
4.8	Events.....	12
4.9	CSM Parameters.....	13
5	Principle of Operation.....	15
5.1	High Quality Amplifier.....	15
5.2	Measurement Principle.....	15
5.3	CSI Scale.....	16
5.4	EMG.....	17
5.5	Burst Suppression Indicator.....	17
5.6	Artefact and Noise Control.....	17
6	CSM Battery / Mains Operation.....	18
7	Data Recording via CSM Link.....	20
7.1	CSM Link Software (Optional).....	20
7.2	CSM Link.....	20
8	Specifications.....	22
9	Accessories.....	23
10	Maintenance.....	23
11	Troubleshooting.....	25
12	System and Error Messages.....	27
13	Safety and Warranty.....	27
14	Service and Contacts.....	29

This manual is published by Danmeter A/S, who reserves the right to improve and modify the contents without prior notice. Modifications will, however, be published in future editions. All rights reserved.

Cerebral State Monitor, CSM & CSI are trademarks of Danmeter A/S

Products manufactured by Danmeter A/S, Kildemosevej 13, DK-5000 Odense C, Denmark

English

PN 561100006-03

**Declaration of Conformity:**

Danmeter A/S hereby declares that the Cerebral State Monitor complies with the following standards:

EN (IEC) 60601-1, EN (IEC) 60601-1-2, EN (IEC) 60601-2-26

Following the provisions of 93/42/EE

## I About this Manual

This manual is intended to assist the user in operating the Cerebral State Monitor (CSM) in a safe and effective manner.

This version of the manual was originally drafted, approved and supplied by Danmeter A/S in English.

Before operating the monitor read this manual thoroughly, with particular attention to all warnings and cautions.

**Note:**

Although the monitor is built and tested to exacting specifications, it is not intended to replace the supervision of level of consciousness monitoring by medical personnel. The user should become thoroughly familiar with the features, operations, and accessories of the monitor and exercise vigilance in its utilization.

- WARNINGS** are directions which, if not followed, could cause fatal or serious injury to an operator, patient or any other person.
- CAUTIONS** are directions which, if not followed, could cause damage to the equipment described in this manual and/or any other equipment or goods, and/or cause environmental pollution.
- NOTES** are intended to highlight unusual points as an aid to the operator.

### I.1 Indications for Use

The monitor is intended for use in monitoring the hypnotic state of the brain by data acquisition of EEG signals of the anaesthetized or sedated patient in all areas of the hospital. The monitor is a non-invasive measurement tool to be used by a trained professional to measure the level of consciousness during general anaesthesia and sedation by use of variations in the frequency content of the spontaneous EEG. It analyses the frequency shifts that take place in the EEG signal as the level of consciousness changes. Based on this principle, the monitor calculates the Cerebral State Index (CSI), which is used to estimate the level of consciousness of the patient.

## 1.2 List of Symbols



Type BF equipment



Stand-by operation (On / Off)



Attention, consult accompanying documents



Do not dispose of in refuse collection. Dispose of at a recycling station or equivalent in accordance with directive 2002-96-EC WEEE.

## 2 Installation and Preparation

The Cerebral State Monitor system consists of:

The Cerebral State Monitor
User manual (this document)
Rechargeable 9V battery
CSM Power
Patient cable
Carrying case
Velcro strip (42mm x 25mm)
Clip for patient cable

For further equipment please refer to the accessories list in chapter 9.

### Note:

The CSM monitor's EEG acquisition performance, and its processing and calculating of the CSM parameters and waveforms are **ONLY** guaranteed by the manufacturer when using the CSM Procedure Pack, part no. DMX005

Using standard ECG electrodes is **NOT RECOMMENDED**

### 3 Skin Preparation and Sensor Positioning

To ensure low sensor impedance, cleanse skin using mild soap and water.

**Note:** Alcohol is not recommended as a skin cleanser; it leaves a film layer that may cause high sensor impedance. If alcohol is used, ensure 30 seconds drying time.

The CSM Procedure Pack contains a skin preparation product and 3 neuro sensors.

**Note:** The performance of the CSM is only guaranteed by the manufacturer when the CSM Procedure Pack is used.

Dry-abrade the skin gently using the skin prep product or with a dry wash cloth or gauze, to remove the non-conductive skin layer. See diagram below.

**Caution:**

- Make sure no part of the sensors is in contact with any other conductive parts including earth/ground.
- If skin rash or other unusual symptoms develop, remove sensors from patient.
- Change sensors every 24 hours to check skin integrity.

Position the three sensors from your CSM Procedure Pack according to the diagram below:

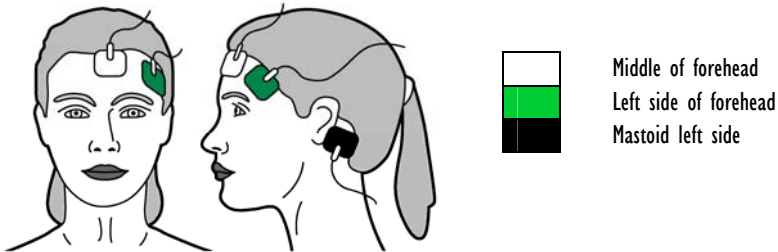

The diagram above shows a left-sided setup; right-sided is also acceptable. Place sensors at the side furthest from the surgical area.



The advanced signal processing of the monitor ensures that a deviation in the positioning of the sensors up to 2 cm (0.78 in) has no significant influence on the index. However, it is recommended to place the sensors on an area of the skull where only a few muscle fibres are present in order to achieve the best quality signal.

**Note:** Once the sensors have been secured to the skin, attach the colour-coded wires on the patient cable to the appropriate sensor.

## 4 Description of the Device

### 4.1 General Overview

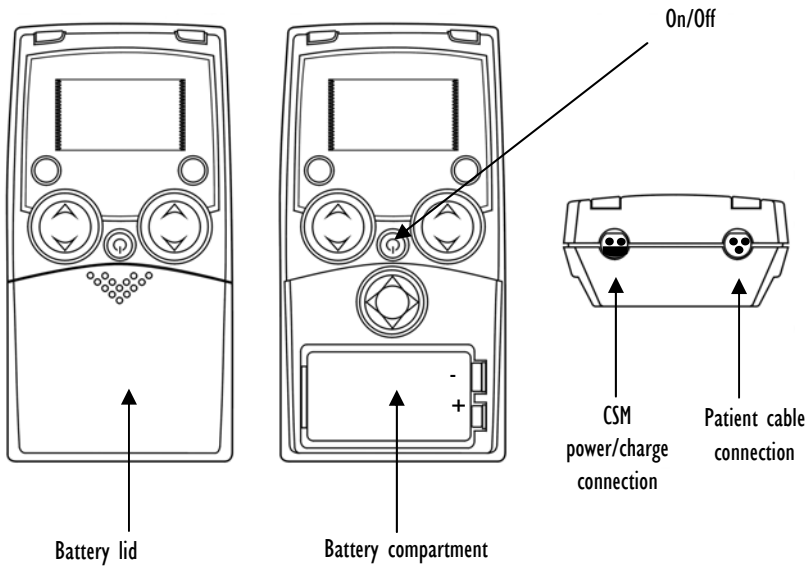

## 4.2 Keys and Controls Overview

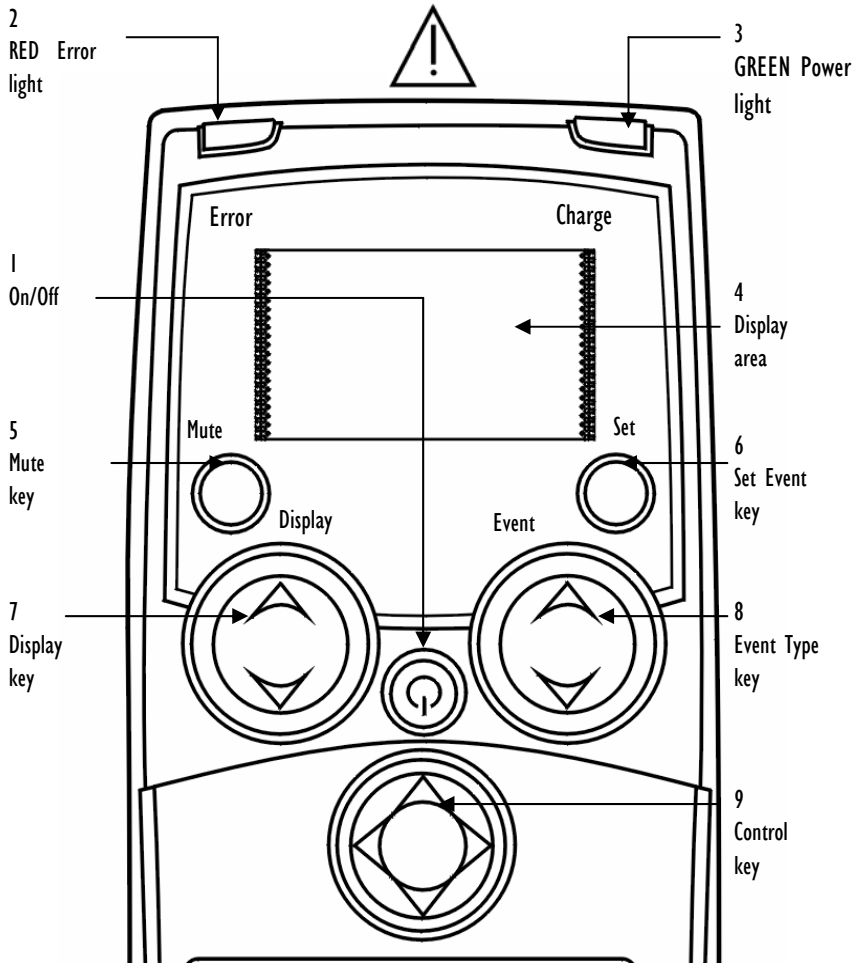

### 4.3 Light Indicators

#### 2 RED Error light

Lights up when sensor error situations are detected

#### 3 Lights when mains is connected

### 4.4 Description of Keys



1 Power On  
Press once



1 Power Off  
Press and hold until "Power Off" bar disappears



1 Wireless Link connection, disconnection or reconnection  
Press twice within 1 second



5 Mute key  
Mutes alarms



6 Set Event key / Set link (accessory)



7 Display key  
Changes between graphical and information screen



7a - For immediate impedance update



8 Event key  
Select event type / Select link (accessory)



9 Control key  
Used for menu selection of parameter settings



9a - Use the Control key to scroll in the menus or set values



9b - Select a submenu or function



9c - Go back one menu level



## 4.5 Operation Display Modes

The CSM always starts up with display A.

Switch between displays A, B, C, D and E by pressing the Display key (7).

### Mode D

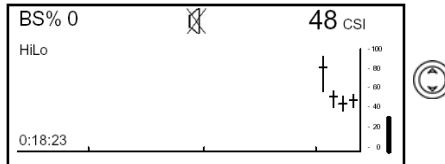

CSI trend histogram with 5-minute interval showing average, lowest and highest CSI values within the interval. EMG% is displayed as a bar in the right panel.

### Mode C

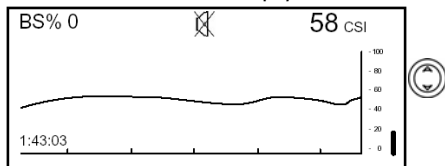

CSI trend curve with event markers and BS curve. EMG% is displayed as a bar in the right panel. Operation time and numeric value of the actual CSI and BS%. The time scale for the trend curve is 5.27 minutes and each tag is 60 seconds.

### Mode B

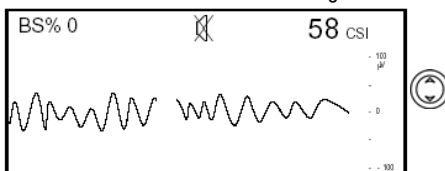

Displays 3 seconds of EEG waveform. Use Event key (8) to scale up and down. EEG scales are  $\pm 200 \mu\text{V}$ ,  $\pm 100 \mu\text{V}$  (default),  $\pm 50 \mu\text{V}$ ,  $\pm 20 \mu\text{V}$  and  $\pm 10 \mu\text{V}$ .

### Mode A

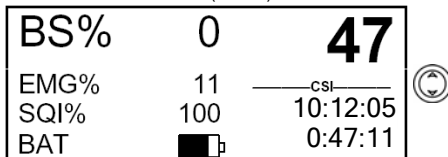

Main information window with CSI, BS%, EMG%, SQI%, clock, operation time and battery operation.

### Mode E

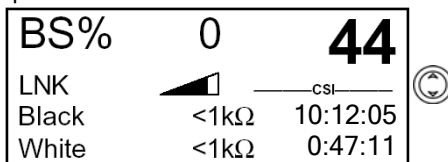

Sensor impedance, CSI, BS%, clock and operation time. When display E is active, the sensor impedance is updated every 60 seconds. Press Display key (7a) firmly for immediate impedance update.

The EEG waveform is derived from the signal recorded between the frontal and mastoid electrodes. The frequency content is 2-35 Hz. If the EEG amplitude is low, then in some conditions the ECG might be detectable in the EEG waveform.

Operating time and numerical value for current CSI and BS%. The time scale for the histogram graph is 180 min. The interval between each tag is 60 min. The high-low bar in the current time interval (high-low bar to the far right) is updated dynamically.

### Special display features

	Artefact	Sensor alarm
CSI	- -	-?-
BS%	- -	-?-
EMG	- -	-?-
SQI	SQI value	-?-

## 4.6 Setup Menu

### General menu structure and menu selections

#### Top Menu

BS% 0	47 CSI
Menu	1
<b>Alarm</b>	
Config	
Device information	

#### How to select menu settings from Display Mode

1. Remove battery lid.
2. From any Display Mode, press any arrow on the Control key (9).
3. The top menu appears.
4. *Note:* The last menu used is chosen.

#### How to set parameter values

1. Press the Control key (9a) to select menu.
2. Press the Control key (9b) to enter submenu.
3. Press the Control key (9a) to select parameter.
4. Press the Control key (9b) to highlight parameter value.
5. Press the Control key (9a) to select parameter value.
6. Press the Control key (9b) to store setting or (9c) to cancel the selection and return without any change.
7. Press the Control key (9c) to go back in one menu level steps.

If the Control key has not been activated in 20 sec. the CSM returns to Operation Display Mode and stores the settings.

#### Note:

The change of settings will only be stored for future use after returning to Operation Display Modes.

## 4.7 Settings

Parameter	Menu	Description	Values (Default)
High Alarm	Alarm	Selects the CSI Alarm High Option	ON/OFF (OFF)
Low Alarm	Alarm	Selects the CSI Alarm Low Option	ON/OFF (OFF)
High Limit	Alarm	Selects the CSI High Alarm Level	2-99 (60)
Low Limit	Alarm	Selects the CSI Low Alarm Level	1-98 (40)
Language	Config	Selects device language	English
Contrast	Config	Selects display contrast	15-35 (20)
RF interface	Config	Select radio link active. If turned OFF the link is completely inactive.	ON/OFF (ON)
Set clock	Config	Sets clock: Date Format, Year, Month, Date, Hours, Minutes, Seconds	
Back light	Config	Sets display light and light brightness	0 = Off 1 = Normal (1) 2 = Bright
AutoLNK	Config	Automatically establishes a wireless link to any CSM link within approx. 3 meters or to a specified CSM link	Inactive/Active/SN (Inactive) SN is only displayed if link is established

### The AutoLNK function

When AutoLNK is set to **Inactive**:

- active CSM Link(s) within range will pop-up in the Link display. Select the CSM Link serial number you would like to connect to.

When AutoLNK is set to **Active**:

- active CSM Link within range will automatically be connected to CSM monitor.

When AutoLNK is set to **SN**:

- CSM monitor automatically connects to the dedicated CSM Link if within range.

## Device Information:

Select submenu

BS% 0	47 CSI
Device information	1
<b>Info</b>	
Link	
Log	

Info:

- Serial number
- SW version
- CSI version
- AD version

Link:

- - indicates no CSM Link connected
- If CSM Link connected the CSM Link serial number and software version will be shown

Log:

- Serial number
- #1 total no. of CSM sessions
- #2 total no. running hours

## 4.8 Events

Pressing the Set Event key (6) results in a continuously numbered event with no description being displayed. Pressing the Event Type key brings up the following selection menu:

BS% 0	47 CSI
Event types	1
<b>Induction</b>	
Intubation	
Maintenance	

The following event description options can be selected: Induction, Intubation, Maintenance, Surgery, Injection, Note, End Maintenance and Movement.

When the desired option has been selected, press the Set Event key (6) to confirm. If no selection is made within 5 seconds the system returns to the current Display Mode. Only the event numbers are visible on Display Mode C. Event names will only be displayed when using the CSM Link option.

Events can be set with intervals of 3 seconds.

## 4.9 CSM Parameters

### BS% Indicator

The amount of Burst Suppression (very low-amplitude or “flat” EEG) is displayed in all Display Modes at the top left hand side. Please refer to Section 5.5 for further information on the BS% measurement.

### EMG% and EMG bar

The EMG level is displayed either as a numerical percentage (0-100%) value in Display Mode A or graphically as a bar at the right hand side in Display Mode C and D. Please refer to Section 5.4 for further information on the EMG measurement.

### Signal Quality Indicator (SQI%)

SQI% measures the quality of the acquired EEG signal. The calculation is based on a number of artefacts during the last minute. The electrode-to-skin impedance is included in the SQI% calculation. Higher electrode-to-skin impedances reduce the SQI%. Only electrode-to-skin impedances at  $1\text{ k}\Omega$  and  $1\text{ k}\Omega$  will result in a SQI% of 100. This quantity is displayed numerically as a percentage (0-100%, 100% equals best signal quality) in Display Mode A.

If the impedance of the white or black sensors exceeds  $1\text{ k}\Omega$ , the SQI will fall gradually. Poor impedance conditions may cause the SQI to fall to 50%.

### Sensor Impedance

The impedance of the white and black sensors is continuously measured and displayed in Display Mode E. Low sensor impedance values (typically between  $1$  and  $3\text{ k}\Omega$ ) are essential for good monitor operation. A “ $<1\text{ k}\Omega$ ” readout means that sensor impedance is optimal.

### Sensor Alarm

The Sensor Alarm signals the interruption of reliable CSI calculation due to corrupted or interrupted EEG. This is usually caused by the use of diathermia or a faulty sensor connection (high sensor impedance or disconnection of sensor leads). Should any of these situations occur, the Red Error light (2) will turn on. The CSI is not calculated during these periods, but is replaced by -?-.

### Alarms (High / Low)

Alarms can be set to signal the moment when the CSI rises above and/or falls below preset limits. The High and Low Alarms can be turned on or off from the Alarm Menu, where the High and Low Alarm limits can also be set. The High Alarm is ONLY activated when the current CSI has been lower than the High Alarm value. This is convenient when the High Alarm is set in the awake patient. If High Alarm is set to 60 and High Alarm ON, then the CSI must be lower than 60 once before the High Alarm is activated. If the current CSI goes higher than 60 the CSM monitor alarm sounds.

The same functionality is present for the Low Alarm.

## Battery Symbol

An icon labelled “BAT” in Display Mode A indicates the remaining battery capacity. For further information on battery operation of the CSM, please see section 6.



Battery about 50-percent charged



Battery charging when icon animates



Battery fully charged (if not animated)

### Note:

ONLY a CSM Battery (CSMX04) is to be charged in the CSM Monitor

## LINK Signal Symbol

An icon labelled “LNK” in Display Mode E indicates the state of the data transfer connection via the CSM Link. For further information on the CSM Link feature, please see section 7.

### Acoustic signals

Start-up	3 beeps
Event	1 beep
Alarm (High/Low)	2 beeps per sec. (Mute = mute 60 sec.)
Low Battery	2 beeps per sec. (Mute = mute 60 sec.)

## 5 Principle of Operation

### 5.1 High Quality Amplifier

An instrumentation amplifier collects ongoing EEG with a high Common Mode Rejection Ratio ensuring a high-quality EEG acquisition. Special artifact detection algorithms are used to eliminate their effects on subsequent CSI calculations.

### 5.2 Measurement Principle

The performance of the CSI is based on the analysis of the frequency content of the EEG signal.

The energy of the EEG is evaluated in specific frequency bands. These are used to define two energy ratios called alpha ( $\alpha$ ) and beta ( $\beta$ ). Both of these show a shift in energy content from the higher to the lower frequencies during anaesthesia. The relationship between these quantities is also analysed as a separate parameter ( $\beta$ - $\alpha$ ).

$$\alpha_{ratio} = \ln \frac{E_{30-42.5Hz}}{E_{6-12Hz}} \qquad \beta_{ratio} = \ln \frac{E_{30-42.5Hz}}{E_{11-21Hz}}$$

The monitor also on-line evaluates the amount of instantaneous burst suppression (BS) in each thirty-second period of the EEG. This measurement quantifies the amount of “silent” or “flat” EEG periods characteristic of the deepest levels of hypnosis.

These four parameters are used as input to a fuzzy logic classifier system that calculates the Cerebral State Index.

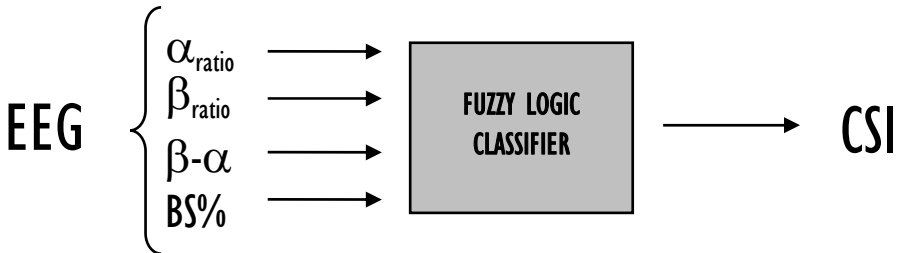

### 5.3 CSI Scale

The CSI is a unit-less scale from 0 to 100, where 0 indicates a flat EEG and 100 indicates EEG activity corresponding to the awake state. The range of adequate anaesthesia is designed to be between 40 and 60. All values in the table are approximate values based on the mean values of the patient behaviour.

The relationship between the CSI, the clinical state and the OASS<sup>1</sup> score is shown in the table below:

CSI	Clinical State	OASS
90-100	Awake	5
80-90	Drowsy	4
60-80	Light anesthesia or sedation	3
40-60	Range considered as adequate for surgical anesthesia	2-1
10-40	Deep anesthesia, in most cases accompanied by burst suppression	1
0-10	Close to coma, BS (burst suppression) larger than 75. When CSI is below 3, the EEG is practically iso-electric.	<1

The prediction probability (Pk) between the CSI and the OASS was 0.92.

The OASS score correspond to:

OASS	Clinical State
5	Responds readily to name spoken in normal tone
4	Lethargic response to name spoken in normal tone
3	Responds only after name called loudly and/or repeatedly
2	Does not respond to mild prodding or shaking
1	Does not respond to noxious stimulus

---

<sup>1</sup> Observers Assessment of Alertness and Sedation

## 5.4 EMG

High levels of facial muscular or electromyographic (EMG) activity can interfere with the CSI under certain circumstances. The monitor incorporates an EMG filter that removes most of the potential interfering EMG activity. The EMG bar shows the energy of the EMG level in the 75–85 Hz frequency band (0–100 logarithmic). The bar is located on the right side of the display.

EMG activity is expected to be present when the patient is awake. When the patient is asleep, EMG activity can increase due to:

- Reflex reactions to painful stimuli during surgery
- Lack of muscular relaxation
- Muscular rigidity caused by some opioids (analgesics)
- Presence of large external electrical fields, e.g. diathermy

The EMG bar should be checked frequently, especially in case of a sudden increase in the CSI. If the increase in CSI is accompanied by an increase in muscular activity, there is a risk that EMG is causing interference. When this happens, attention must be paid to the stimuli received by the patient during surgery. In the presence of hypnotically unrelated EMG, administration of a neuromuscular blocking agent will cause the CSI to decrease. Since patients receiving neuromuscular blocking agents cannot exhibit movement as a sign of arousal, the CSI is a valuable tool in their anaesthetic management.

## 5.5 Burst Suppression Indicator

The monitor includes a Burst Suppression indicator to show periods when the EEG is iso-electric or “flat”. The indication appears in the upper left-hand side of the graph window in the display and shows the percentage of burst suppression over the last 30 seconds of the EEG signal. A BS% = 20 readouts means that the EEG has been iso-electric during 20% of the last 30 seconds.

## 5.6 Artefact and Noise Control

The artefact rejection algorithm ensures that the incoming EEG is not contaminated with noise. When excessive noise is detected, the signal quality index is reduced reflecting the disturbance. The artefact rejection algorithm will be active especially when diathermy and equipment creating external interference is used.

## 6 CSM Battery / Mains Operation

The CSM can be operated in two different modes

- Battery operated
- Mains operated

### Warning:

Only standard alkaline batteries or CSM rechargeable battery CSMX04 must be used.

### Battery operation (alkaline batteries)

- Always use new alkaline batteries to ensure best results
- Insert battery correctly

### Mains operation and CSM rechargeable batteries

### Warning:

Only for use with adapter CSMX05 (Ault Inc., Model MW117)

### Note:

There is no alarm if the battery is not connected. If no battery is inserted, the monitor is switched off when the external CSM Power is removed. There is no internal back-up battery in the monitor.

### Note:

The clock is powered by an internal battery with a limited life (minimum 6 years from date of manufacture). When the battery is used up, the clock will be reset, and the clock will blink on start up. The monitor should then be sent for service

### Battery Lifetime (Fully charged, CSMX04 only)

Wireless Link	Backlight level	Lifetime (hours)
OFF	OFF	10.5
OFF	1	9.0
OFF	2	7.0
ON	OFF	10.0
ON	1	8.5
ON	2	6.5

### Note:

If 9V alkaline disposable batteries are used, the battery lifetime indicated in the table can be 2 to 3 times longer.

## CSM Power

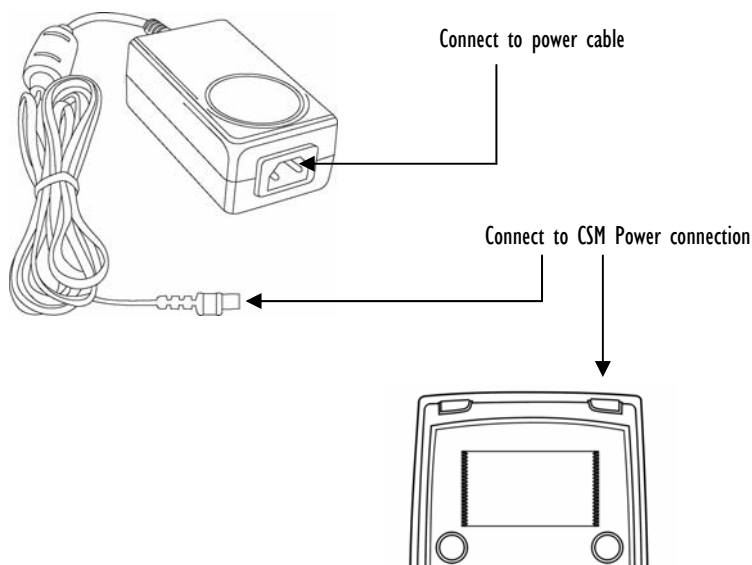

1. Insert the CSM rechargeable battery as indicated
2. Connect mains cable to mains and turn on power
3. Green indicator (3) lights up
4. Turn on monitor
5. When the CSM is connected to an electrical outlet, and turned on, the CSM can be operated while the CSM battery is charged. If power is disconnected, the CSM will continue running on the CSM battery.

### Electrical Operation Only

The CSM can be operated on mains with the CSM Power, with or without any type of approved battery inserted.

#### Note:

When a CSM rechargeable battery (CSMX04) is used, it will charge automatically while the electrical power is connected. **ONLY** a CSM Battery (CSMX04) is to be charged in the CSM monitor

## 7 Data Recording via CSM Link

### 7.1 CSM Link Software (Optional)

The real-time data capturing software for the Cerebral State Monitor makes it possible to record online data wireless via the CSM Link. The following data is recorded:

- CSI
- BS
- EMG
- Sensor impedance
- SQI
- EEG

CSM automatically saves the last 18 hours of data and a maximum of 10 cases, regardless of the state of the wireless link (on or off).

### 7.2 CSM Link

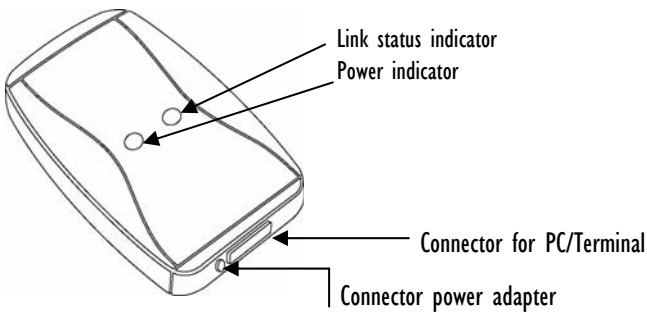

Description of CSM Link Indicators:

Power:	Power	
Link:	Flashing:	Link selected
	Constant:	Link established

## Connecting CSM Monitor and CSM Link

1. Turn on the CSM Link.
2. Power indicator shows a constant light.
3. Link indicator is off.
4. Turn on the CSM monitor.
5. The CSM monitor shows a list of CSM Links found.
6. Select CSM Link ID (Serial No.) with the Event key (8) and the indicator Link flashes, or choose skip in order not to establish a connection. (The radio is reactivated by pressing the Power On key (1) twice or the next time the CSM is switched on.)
7. Accept the CSM Link by pressing the Set Event key (6).
8. When link has been established the indicator Link will show a constant light.

## Disconnecting CSM Monitor and CSM Link

1. Press Power On key twice within one second.
2. Highlight release using Event key (8).
3. Press Set Event key (6) to disconnect. CSM radio is inactive. (The radio is reactivated by pressing the Power On key (1) twice or the next time the CSM is switched on.)

## Connecting to CSM Link when the CSM radio is inactive

1. Turn on the CSM Link.
2. Power indicator shows a constant light.
3. Link indicator is off.
4. Press Power On key twice within one second.
5. The CSM monitor shows a list of CSM Links found.
6. Select CSM Link ID (Serial No.) with the Event key (8) and the indicator Link flashes, or choose skip in order not to establish a connection.
7. Accept the CSM Link by pressing the Set Event key (6).
8. When link has been established the indicator Link will show a constant light.

### Note.

If wireless has been active for more than five minutes without any connection to CSM Link, the radio is deactivated.

## 8 Specifications

EEG sensitivity	±400 µV	
Noise	< 2 µV <sub>p-p</sub> , < 0.4 µV RMS, 1–250 Hz	
CMRR	> 140dB	
Input impedance	> 50Mohm	
Sample rate	2000 samples/sec. (14 bits equivalent)	
CSI and update	0-100. Filter 6-42 Hz, 1 sec. update	
EMG	0-100 logarithmic. Filter 75-85 Hz, 1 sec. update	
BS%	0-100%. Filter 2-42 Hz, 1 sec. update	
Digital output	Wireless to RS232 link or USB (ISM 2.4 GHz)	
Wireless range	Up to 10 meters	
Display size	32x17 mm	
Alarms	High / Low with user selectable limit	
Artefact rejection	Automatic	
Sensor impedance range	0-10kOhm / measurement current 0,01 µA	
Battery	9V Alkaline or rechargeable NiMH (6AM6/IEC:6LR61/ANSI:1604A )	
Supply current	30mA (typical)	
Max. battery lifetime - Alkaline	30h (stand alone) 18h (transmitting wireless)	
Max. battery lifetime - Rechargeable	See table in section 6	
Charging time	4 Hours (CSMX04 only)	
Weight	130 g with battery	
Dimensions	114x60x31 mm	
Classification	Internal power supply/ Class II, type BF, continuous use	
Sensors	Danmeter Neuro Sensors™	
Cable length	195 cm/77" with 35 cm/14" split	
Mounting options	Velcro strip (42mm x 25mm)	
Memory	Data recording 18 hours	
Environment — Operation	Temperature	10–40°C/50–104°F
	Rel. humidity	30–75%
	Air pressure	700–1060 hPa
Environment — Transport and storage	Temperature	10–40°C*/50–104°F
	Rel. humidity	30–95%
	Air pressure	700–1060 hPa
* If transport without sensors: -20–70°C (-4–158°F)		

## 9 Accessories

CSMX04	CSM rechargeable battery
CSMX05	CSM Power/Charger
CSMX06	Patient cable
CSMX09	Carrying case
CSMX10	Service manual, English
CSMX11	CSM Link Software
CSMX12	CSM Link RS-232
CSMX19	CSM Link USB
CSMX18	CSM Link PHILIPS VOI
CSMX13	Velcro Strip (42mm x 25mm)
DMX004	RS-232 cable
DMX013	USB cable
DMX005	CSM Procedure Pack™
DMX007	Clip for patient cable
CSMIUK	User manual

## 10 Maintenance

### Routine Maintenance

To ensure the monitor remains in good operating condition, it is important to keep it clean and carry out the routine maintenance procedures described below. There are no serviceable parts in this instrument and all service is to be carried out by the manufacturer.

#### Note:

If the monitor is dropped, damaged or subjected to excessive moisture or high temperature, it should immediately be taken out of service for examination by qualified service personnel.

Interval	Routine Maintenance Procedure
As required	Clean the external surfaces of the monitor thoroughly before and after a prolonged period of storage
Every 12 months	1. Inspect power adapter plug and cable for damage. 2. Perform electrical safety checks (including leakage current measurement)

## Cleaning

Clean the monitor periodically by wiping the outer case with a lint-free cloth lightly moistened with warm water and a mild, non-abrasive cleaning solution or 70% isopropyl alcohol.

### Note

The monitor case is resistant to the following cleaning solutions:

- Renu-klenz 16ml/L (Steris corp., USA)
- Vesphene lise 8ml/L (Steris corp., USA)
- Warm water
- Isopropyl alcohol 99%
- Acetone 10%
- Hydrogen peroxide 3%

## Storage

If the monitor is to be stored for a longer period, it should first be cleaned and the battery removed. Store in a clean, dry atmosphere at room temperature and, if available, use the original packaging for protection.

## Fuses

### Caution:

No user-replaceable fuses in the monitor or CSM power

## Disposal

The monitor should be disposed of taking into consideration environmental factors, local laws and regulations. All components can be safely disposed of in the approved manner as per hospital or locally regulated guidelines. Remove battery, if any, before disposal.

## Test Routines

Refer to Service manual CSMX10

## 11 Troubleshooting

### **CSM does not turn on when power key is pressed?**

Change to a new battery or a fully recharged battery.

If changing the battery does not help, send the CSM for service.

### **Sensor alarm — Red Error light turns on and CSI, BS and EMG replaced by -?-**

Check all sensors and their connections. This alarm can also be caused by diathermy — see section 5.6.

Check the patient cable.

If not connected, then connect it.

If faulty, replace patient cable.

Check if either of the sensors are disconnected or badly connected.

Replace faulty sensor

### **Blanked index — but why?**

#### **Sensor impedance too high**

If sensor impedance is  $>5k\Omega$  the CSI, BS and EMG will be blanked (- - displayed).

Check that sensors are not dry.

Check that the skin has been cleaned properly.

Clean skin as described in section 3 and attach new sensors.

#### **Signal Quality Index (SQI) low**

If the impedance of the white or black sensors exceeds  $1k\Omega$ , the SQI will fall gradually. Poor impedance conditions may cause the SQI to fall to 50%.

Artefacts can have many causes: diathermy, EMG, etc. are typical causes.

If SQI falls because of extensive use of diathermy, it will rise as soon as the diathermy is stopped.

Check that all sensors and cable connections are correctly connected.

Has the use of any mechanical device that could generate high frequency activity (e.g. patient warmer) been initiated or is any such device in close proximity to the CSM sensors?

If possible move disturbing device away from the sensors.

Check grounding of disturbing device.

Reduce the influence from disturbing device by disconnecting CSM Power to let the CSM run from the battery.

### **CSI is higher than expected**

Check anaesthetic delivery systems: IV lines and status of vaporizers.

Some patients require a higher dose of drugs due to interpatient variability.

Adequate dosing for maintenance may not be sufficient for increased stimulation.

### **CSI rises along with EMG**

High levels of facial muscular or electromyographic (EMG) activity can elevate the CSI under certain circumstances. When this happens, attention must be paid to the stimuli received by the patient during surgery. When the patient is asleep, EMG activity can increase due to reflex reactions to painful stimuli during surgery, lack of muscular relaxation or muscular rigidity caused by some opioids (analgesics). In the presence of hypnotically unrelated EMG, administration of a neuromuscular blocking agent may cause the CSI to decrease.

#### **Note:**

Facial muscles will recover sooner than skeletal muscles.

When these artefacts are present, the CSI should be interpreted with caution.

### **Communication**

#### **POWER indicator on CSM Link does not turn on when power is connected**

Check power connection.

Replace power cable or try alternate outlet. If POWER indicator is still not on, send CSM Link for service.

#### **LINK indicator on CSM Link Does not turn on**

Check that this actual CSM Link is chosen on the CSM.

If CSM cannot find the CSM Link:

Relocate CSM Link to obtain better signal quality.

Turn on RF communication in the CSM.

#### **CSM and Link are connected but no data appears on recording terminal**

Check that the RS-232 or USB is connected.

Check that the recording terminal has the right setup.

## 12 System and Error Messages

For error codes (1-10 and 14) shown in the display, contact the appropriate service or distribution centre. See section 14.

Together with the error code an audible alarm is activated.

Error codes 11, 12 and 13 can occur if the patient cable or the electrodes are connected while the CSM is performing the start up check. Take the following action:

1. Turn off the CSM.
2. Disconnect patient cable.
3. Turn on the CSM
4. When the start up check has finished connect the patient cable for normal operation.

## 13 Safety and Warranty

### Warnings

- Not to be used in the presence of flammable gases; explosion risk.
- When used with High Frequency (HF) surgery please note the positioning of the sensors (see page 3). In order to reduce the hazard of burns the sensors should not be located between the surgical site and the electro-surgical unit return sensor.
- Pay attention if the monitor is connected to a patient connected to other equipment. The total of leakage current may exceed the allowable limit and cause a possible hazard to the patient.
- The conductive parts of sensors and their connectors, including the neutral sensor, should not contact other conductive parts including earth.

### Cautions

- The monitor should be used in conjunction with other patient monitoring parameters and clinical signs. This will ensure the optimum balance of the anaesthesia/sedation administration.
- Do not open the instrument case. There are no user-serviceable parts inside. The case should only be opened by qualified service personnel using proper grounding techniques. When the case is opened, an electrical shock hazard exists which can result in serious injury to persons and instrument component damage.
- Disconnect from battery power when performing maintenance.
- Should an instrument be dropped or severely shaken, it should immediately be taken out of service and inspected by qualified service personnel to ensure its proper function prior to use.
- Operating the monitor close to equipment radiating high-energy radio frequencies (electrosurgical/cauterizing equipment, portable radios, cellular telephones, etc.) may cause Signal

Disturbance. If this happens, reposition the monitor away from the source of interference. See section 5.6 for additional information on artefacts.



- Do not allow fluids to spill or drip on the monitor.
- Do not use the monitor when cardiac defibrillator is used.
- Patient cables are not protected against defibrillation.

### **Special Patient Populations**

The monitor will not render accurate readings when used on patients with severe neurological disorders and patients under 2 years of age.

The use of pacemakers might cause either long periods of artefacts or elevated CSI values.

### **Warranty**

DANMETER warrants that:

- The monitor is free from defects in material and workmanship under normal use and service for a period of 24 months from the date of delivery by Danmeter to the first purchaser.
- Accessories are free from defects in material and workmanship under normal use and service for a period of ninety (90) days from the date of delivery by Danmeter to the first purchaser.

If any product requires service during the applicable warranty period, the purchaser should communicate directly with the local Danmeter service centre to determine the appropriate repair facility. Repair or replacement will be carried out at Danmeter's expense, subject to the terms of this warranty. The product requiring service should be returned promptly, properly packed, and postage prepaid. Loss or damage in return shipment to Danmeter shall be at purchaser's risk.

In no event shall Danmeter be liable for any incidental, indirect or consequential damages in connection with the purchase or use of any Danmeter product.

This shall apply solely to the original purchaser. This warranty shall not apply to any subsequent owner or holder of the product. Furthermore, this warranty shall not apply to, and Danmeter shall not be responsible for, any loss arising in connection with the purchase or use of any Danmeter product that has been:

- repaired by anyone other than an authorized Danmeter service representative;
- altered in any way so as, in Danmeter's judgement, to affect its stability or reliability;
- subject to misuse or negligence or accident, or which has had the serial or lot number altered, effaced or removed; or
- improperly maintained or used in any manner other than in accordance with the instructions furnished by Danmeter.

This warranty is in lieu of all other warranties, express or implied, and of all other obligations or liabilities of Danmeter, and Danmeter does not give or grant, directly or indirectly, the authority to any representative or

other person to assume on behalf of Danmeter any other liability in connection with the sale of Danmeter products.

DANMETER DISCLAIMS ALL OTHER WARRANTIES, EXPRESSED OR IMPLIED, INCLUDING ANY WARRANTY OF MERCHANTABILITY OR FOR FUNCTION OF FITNESS FOR A PARTICULAR PURPOSE OR APPLICATION.

## 14 Service and Contacts

For service, please contact Danmeter or the appropriate service or distribution centre to obtain a unique Service ID number for the CSM.

Before returning the device for service please carry out the following:

- Carefully describe what is wrong with the monitor.
- Clean the monitor before shipping it.
- Use only original packaging for return shipment.
- Include all accessories used when error occurred except used sensors.

Return the Monitor to Danmeter A/S or appropriate service or distribution centre.

### Note:

The Cerebral State Monitor (CSM) can only be returned with assigned Service ID number.

### Head office:

Danmeter A/S

Kildemosevej 13

DK-5000 Odense C

Denmark

Tel. +45 63 11 29 30

Fax: +45 63 11 29 31

Email: [info@danmeter.dk](mailto:info@danmeter.dk)

[www.danmeter.dk](http://www.danmeter.dk)

Technical description

<b>Guidance and manufacturer's declaration — electromagnetic emissions</b>		
The Cerebral State Monitor CSM is intended for use in the electromagnetic environment specified below. The customer or the user of the Cerebral State Monitor CSM should assure that it is used in such an environment.		
Emissions test	Compliance	Electromagnetic environment — guidance
RF emission CISPR 11	Group 1	The Cerebral State Monitor CSM uses RF energy only for its internal function. Therefore, its RF emissions are very low and are not likely to cause any interference in nearby electronic equipment.  The Cerebral State Monitor CSM is suitable for use in all establishments, including domestic establishments and those directly connected to the public low-voltage power supply network that supplies buildings used for domestic purposes.
RF emission CISPR 11	Class B	
Harmonic emission IEC / EN 61000-3-2	Not Applicable	
Voltage fluctuations/ flicker emissions IEC / EN 61000-3-3	Not Applicable	

<b>Guidance and manufacturer's declaration — electromagnetic immunity</b>			
The Cerebral State Monitor CSM is intended for use in the electromagnetic environment specified below. The customer or the user of the Cerebral State Monitor CSM should assure that it is used in such an environment,			
Immunity test	IEC / EN 60601 test level	Compliance level	Electromagnetic environment — guidance
Electrostatic discharge (ESD) IEC / EN 61000-4-2	±6 kV contact ±8 kV air	±6 kV contact ±8 kV air	Floors should be wood, concrete or ceramic tile. If floors are covered with synthetic material, the relative humidity should be at least 30%.
Electrical fast transient/burst IEC / EN 61000-4-4	±2 kV for power supply lines ±1 kV for input/output lines	Not Applicable	Mains power quality should be that of a typical commercial or hospital environment.
Surge IEC / EN 61000-4-5	±1 kV differential mode  ±2 kV common mode	Not Applicable	Mains power quality should be that of a  typical commercial or hospital environment.

<p>Voltage dips, short interruptions and voltage variations on power supply lines IEC / EN 61000-4-11</p>	<p>&lt;5% <math>U_f</math> (&gt;95 % dip in <math>U_f</math>) for 0.5 cycles</p> <p>40% <math>U_f</math> (60 % dip in <math>U_f</math>) for 5 cycles</p> <p>70% <math>U_f</math> (30 % dip in <math>U_f</math>) for 25 cycles</p> <p>&lt;5% <math>U_f</math> (&gt;95 % dip in <math>U_f</math>) for 5 sec.</p>	<p>Not Applicable</p>	<p>Mains power quality should be that of a typical commercial or hospital environment. If the user of the CSM requires continued operation during power mains interruptions, it is recommended that the CSM be powered from an uninterruptible power supply or a battery.</p>
<p>Power frequency (50/60 Hz) magnetic field IEC / EN 61000-4-8</p>	<p>3 A/m</p>	<p>Not Applicable</p>	<p>Power frequency magnetic fields should be at levels characteristic of a typical location in a typical commercial or hospital environment.</p>
<p>NOTE <math>U_f</math> is the a.c. mains voltage prior to application of the test level</p>			

<p><b>Guidance and manufacturer's declaration — electromagnetic immunity</b></p>			
<p>The Cerebral State Monitor CSM is intended for use in the electromagnetic environment specified below. The customer or the user of the Cerebral State Monitor CSM should assure that it is used in such an environment,</p>			
Immunity test	IEC / EN 60601 test level	Compliance level	Electromagnetic environment — guidance
<p>Conducted RF IEC / EN 61000-4-</p>	<p>3 Vrms 150kHz to 80</p>	<p>3 Vrms</p>	<p>Portable and mobile RF communications equipment should be used no closer to any parts of the Cerebral State Monitor CSM, including cables, than the recommended separation distance calculated from the equation applicable to the frequency of the transmitter.</p> <p>Recommended separation distance</p> $d = 1,2\sqrt{P}$

<p>6</p> <p>Radiated RF IEC / EN 61000-4-3</p>	<p>MHz</p> <p>3 V/m</p> <p>80 MHz to 2,5 MHz</p>	<p>3 V/m</p>	$d = 1,2\sqrt{P} \quad 80 \text{ MHz to } 800 \text{ MHz}$ $d = 2,3\sqrt{P} \quad 800 \text{ MHz to } 2,5 \text{ GHz}$ <p>where <math>P</math> is the maximum output power rating of the transmitter in watts (W) according to the transmitter manufacturer and <math>d</math> is the recommended separation distance in meters (m).</p> <p>Field strengths from fixed RF transmitters, as determined by an electromagnetic site survey, (a) should be less than the compliance level in each frequency range (b)</p> <p>Interference may occur in the vicinity of equipment marked with the following symbol:</p> 
<p>NOTE 1</p> <p>NOTE 2</p>	<p>At 80 MHz and 800 MHz, the higher frequency range applies</p> <p>These guidelines may not apply in all situations. Electromagnetic propagation is affected by absorption and reflection from structures, objects and people.</p>		
<p>(a)</p> <p>(b)</p>	<p>Field strengths from fixed transmitters, such as base stations for radio (cellular/cordless) telephones and land mobile radios, amateur radio, AM and FM radio broadcast and TV broadcast cannot be predicted theoretically with accuracy. To assess the electromagnetic environment due to fixed RF transmitters, an electromagnetic site survey should be considered. If the measured field strength in the location in which the Cerebral State Monitor CSM Is used exceeds the applicable RF compliance level above, the Cerebral State Monitor CSM should be observed to verify normal operation, If abnormal performance is observed, additional measures may be necessary, such as reorienting or relocating the Cerebral State Monitor CSM.</p> <p>Over the frequency range 150 kHz to 80 MHz, field strengths should be less than 3 V/m.</p>		

**Recommended separation distances between portable and mobile RF communications equipment and the Cerebral State Monitor CSM**

The Cerebral State Monitor CSM is intended for use in an electromagnetic environment in which radiated RF disturbances are controlled. The customer or the user of the Cerebral State Monitor CSM can help prevent electromagnetic interference by maintaining a minimum distance between portable and mobile RF communications equipment (transmitters) and the Cerebral State Monitor CSM as recommended below, according to the maximum output power of the communications

Rated maximum output power of transmitter W	Separation distance according to frequency of transmitter m		
	150 kHz to 80 MHz $d = 1,2\sqrt{P}$	80 MHz to 800 MHz $d = 1,2\sqrt{P}$	800 MHz to 2,5 GHz $d = 2,3\sqrt{P}$
0,01	0,12	0,12	0,23
0,1	0,38	0,38	0,73
1	1,2	1,2	2,3
10	3,8	3,8	7,3
100	12	12	23

For transmitters rated at a maximum output power not listed above, the recommended separation distance  $d$  in meters (m) can be estimated using the equation applicable to the frequency of the transmitter, where  $P$  is the maximum output power rating of the transmitter in watts (W) according to the transmitter manufacturer.

NOTE 1 At 80 MHz and 800 MHz, the separation distance for the higher frequency range applies.

NOTE 2 These guidelines may not apply in all situations. Electromagnetic propagation is affected by absorption and reflection from structures, objects and people.



